

## Provisional data sheet HTM H2 Rotary Engine

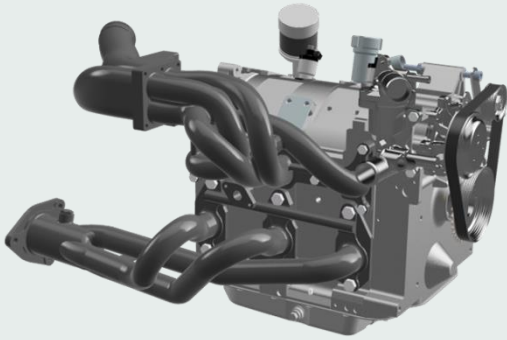

### Compact, Powerful & Cost-Efficient

The HTM H2 Rotary Engine is at the heart of all HTM products and has been specially developed to take full advantage of hydrogen as the fuel of the future. With its high power density and zero-impact emissions, it can be used in hybrid powertrains and in previously unreachable fields of application that were previously reserved for diesel engines.

Technical specifications will follow soon

---

The system is currently under development, which means that specifications may change and will be added to.

If you have any questions about the HTM H2 Rotary Engine, do not hesitate to contact [hofmann@hydrotechnologymotors.de](mailto:hofmann@hydrotechnologymotors.de)